

ONE SERIES

E161i Induction Range (single phase)

Falcon One Series induction is an affordable solution for those kitchens who want to experience the benefits of induction but don't need the high power or performance of Dominator Plus equivalents. Perfect for chefs in operations that have lower demand or service times, including care homes, cafés and coffee shops.

- Affordable induction model
- 6 x 1.5kW cooking zones with 3kW boost function (zones in pairs so boosting one zone takes power from twin)
- Digital display shows each zone's heat setting
- In-built pan detection - no wasted energy
- Induction zones have 10,000 hours lifespan
- Low heat emission
- Instant heat & precise temperature control
- 6mm toughened glass hob plate from which spillages simply wipe clean



Hob Features

- 6 x 1.5kW 180mm heat zones
- 3kW boost function
- 180mm diameter heat zones
- In-built pan detection
- 6mm toughened glass

Oven features

- 4kW burner
- 2 x 2/1GN capacity fan-assisted oven
- Twin doors with glass panels and internal oven lights allow easy monitoring of cooking progress
- Temperature range of 100 - 250°C
- 5 shelf positions
- Vitreous enamelled finish makes it easy to clean oven chamber

Accessories

Included:

- 2 x oven shelves

Optional:

- Oven shelf
- Adjustable castors

Typically found in:

- Care homes
- Small cafés & coffee shops



E161i - Technical Information

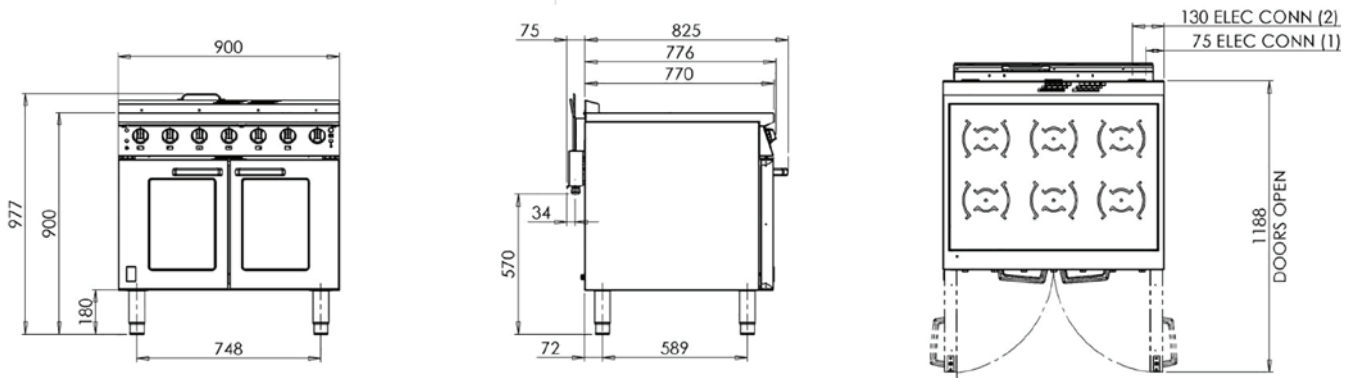

All dimensions in mm;
Height is identical on castors

Specifications

Electrical Rating (kW)	13
Electrical Supply Voltage	230V 1N~
Required Electrical Supply	2 x 32A
Electrical Current Split (amps)	Feed 1 - L: 30.4A Feed 2 - L:26.1A
Heat Zone Rating (kW)	1.5
Oven Element Rating (kW)	4
Oven Dimensions (w x d x h - mm)	700 x 535 x 430
Oven Shelf (w x d - mm)	700 x 535
Gastronorm Compatibility	2/1
Weight (kg)	116
Packed Weight (kg)	137

Installation notes

Adequate ventilation must be provided to supply sufficient fresh air for combustion and to allow easy removal of any such products that may present a risk to health. Please consult current legislation for details that relate to specific locations. Install unit on a level, fireproof surface in a well-lit, draught free position. If floor is made of a combustible material, local fire requirements must be checked to ensure compliance.

A clearance of 150mm should be observed between appliance and any combustible wall.



Falcon Foodservice Equipment, Wallace View, Hillfoots Road, Stirling, FK9 5PY, Scotland

t: +44 (0) 1786 455 200 info@falconfoodservice.com

www.falconfoodservice.com

ONE01-1219