

TECHNICAL DATA SHEET FOR Gas Range Static Oven 600mm

CR6D, CR6C



CR6D

- 600mm wide
- Stainless steel finish
- 5.5kW (18,800Btu/hr) burners
- 2 or 4 open burner configuration
- Cast iron burners and vitreous enamel pot stands
- High crown static oven
- Manual pilot ignition
- Side hinged door
- Welded vitreous enameled oven liner
- Griddle option - 300mm machine finished 12mm thickness, with piezo ignition
- Adjustable front feet and rear rollers
- Fully modular
- Flame failure protection all open burners

Overall Construction

Cooktop

Cast iron open burner heads with vitreous enamelled cast iron caps

Vitreous enamelled potstands

12mm machined surface mild steel griddle plates

Stainless steel front, sides and splashback

Aluminised steel spill tray

Griddle sections are standard on RH side only

Oven

Aluminised oven frame

Fully welded and vitreous enamelled oven liner

GN 1/1 capacity with 4 position racking

Supplied with two chrome plated oven racks

Vitreous enamelled oven spill tray

Vitreous enamelled door inners

Stainless steel exterior door and sides

50mm dia. stainless steel adjustable legs to front and two rollers at rear

Controls

Cooktop

Large easy use control knobs

Variable high to low controls to open and griddle burners

Flame failure on open burners

Griddles standard with pilot, flame failure and piezo ignition

Oven

80-300°C thermostatic oven control

Manual ignition to oven pilot burner with flame failure

Cleaning and Servicing

Easy clean stainless steel exterior

Vitreous enamelled potstands and burner caps

Lift off open burner caps and removable burners

Removable cooktop and oven spill trays

Stainless steel grease trays on griddles

Access to all parts from front of unit

TECHNICAL DATA SHEET FOR Gas Range Static Oven 600mm CR6D, CR6C

Burners

Open Burners;
Natural Gas
5.5kW, 18,800Btu/hr each
LP gas
5.0kW, 17,000Btu/hr each
Griddle Burner;
5.5kW, 18,800Btu/hr each

Oven Burner;
Natural Gas
7.0kW, 23,800Btu/hr each
LP gas
6.5kW, 22,200Btu/hr each

Gas power (gross)

Natural Gas
CR6D 29kW, 99,000Btu/hr
CR6C 23.5kW, 80,200Btu/hr
LP gas
CR6D 26.5kW, 90,400Btu/hr
CR6C 21.5kW, 73,400Btu/hr

Oven Dimensions

Width 460mm
Depth 615mm
Height 365mm

Rack size

450mm x 590mm
Rack positions 4

Gas connection

R³/₄ (BSP) male
130mm from RH side, 20mm from
rear, and 655mm from floor

*All units supplied with Natural and
LP gas regulator*

Dimensions

Width 600mm
Depth 800mm
Height 915mm
Incl. splashback 1085mm

Packing data

0.7m³
Width 640mm
Depth 865mm
Height 1255mm
115kg nett weight
167kg packed weight

Gas types

Available in Natural gas and LP
gas, please specify when ordering

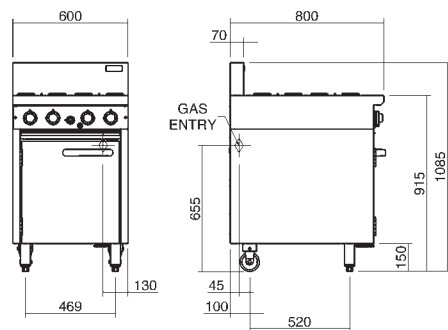

CR6



CR6D

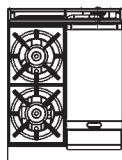

CR6C



www.blue-seal.co.uk

United Kingdom
Blue Seal Limited

Unit 67
Gravelly Business Park
Gravelly
Birmingham B24 8TQ
England
Ph 0121-327 5575
Fax 0121-327 9711
sales@blue-seal.co.uk
www.blue-seal.co.uk

Australia
Moffat Pty Limited

740 Springvale Road
Mulgrave
Victoria 3170
Australia
Ph 03-9518 3888
Fax 03-9518 3833
vsales@moffat.com.au
www.moffat.com.au

New Zealand
Moffat Limited

16 Osborne Street
PO Box 10-001
Christchurch 8011
Ph 03-389 1007
Fax 03-389 1276
sales@moffat.co.nz
www.moffat.co.nz



Designed and manufactured by



ISO9001

All Cobra products are designed and
manufactured by Moffat using the
internationally recognised ISO9001
quality management system,
covering design, manufacture and
final inspection, ensuring consistent
high quality at all times.



In line with policy to continually
develop and improve its products,
Moffat Limited reserves the right to
change specifications and design
without notice.

