



OE8113 - Opus 800
Electric Free-standing
Twin Tank Fryer - 2
Baskets - W 600 mm -
24.0 kW

An accurate Opus 800 Twin-Tank Free Standing Electric Fryer which comes with two independent fryer tanks for greater versatility.

- ✓ Two independent fryer tanks for greater versatility
- ✓ Accurate thermostatic control up to 190°C for consistent results and safe operation
- ✓ Hinged, lift out element, with safety interlock for easy tank access and cleaning

Specifications

Summary

Range Name	Opus 800
Power Type	Electric
Unit Type	Free-standing
Available in UK Only	No
UK Warranty	2 Years Parts and Labour Warranty
Export Warranty	Contact your local dealer
GTIN Code	5056105102960

Power and Performance

Total Power kW	24.0
Temperature Range °C	90 - 190
IP Rating	IP24
Temperature Control	Mechanical

Key Specifications

Capacity Litres	2 x 15.0
Number of Baskets	2
Number of Tanks	2
Gravity Filtration	No
Pumped Filtration	No
Drain Location	Through the body

Weights and Dimensions

Unit Height (External) mm	1020
Unit Width (External) mm	600
Unit Depth (External) mm	800
Net Weight Kg	99

Supply Connections

Requires Installation	Yes
Requires Electrical Supply	Yes
UK 3 Pin Plug	No
Requires Hardwiring	Yes
Electrical Supply Rating Watts	24,000
Three Phase Amps	L1/L2/L3= 34.8 [1 cab]; L1/L2/L3= 2 x 17.4 [2 cab]
Three Phase Voltage	400

Shipping

Packed Weight Kg	111
Packed Height cm	122
Packed Width cm	70
Packed Depth cm	85

Available Accessories

BA122	1/2 BASKET FOR OPUS 800 - 300MM WIDE TANKS
LK02	OPUS 350 LEG KIT
OA8954	SPLASHGUARD FOR OPUS 800 ELECTRIC FRYERS
OF2	Oil filter kit - size 2

Technical Picture

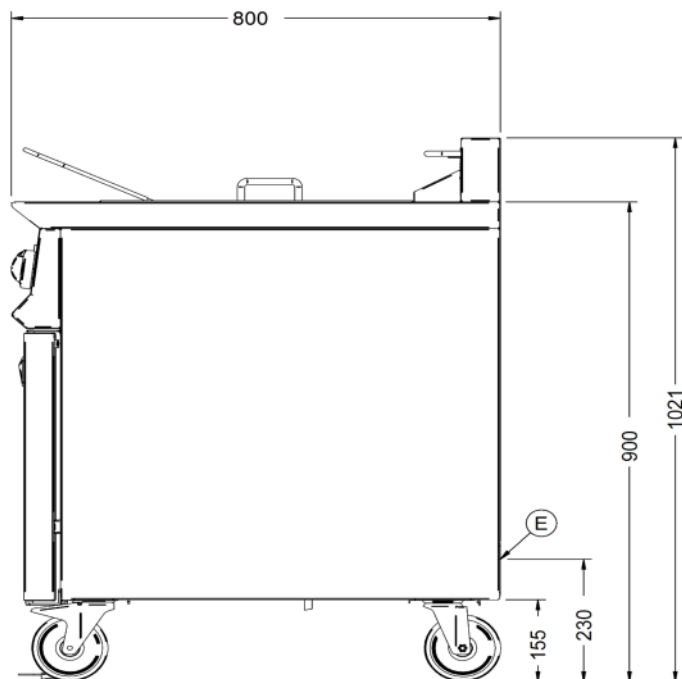
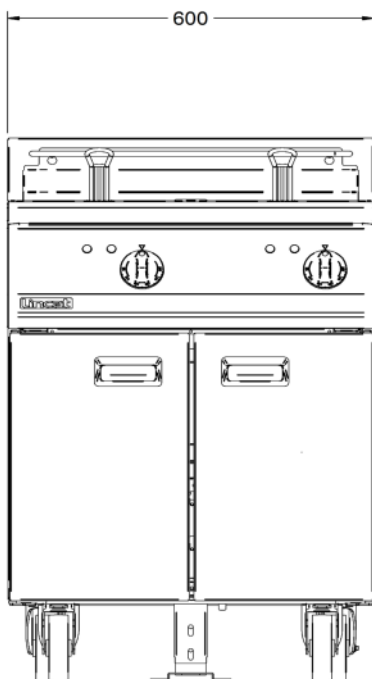
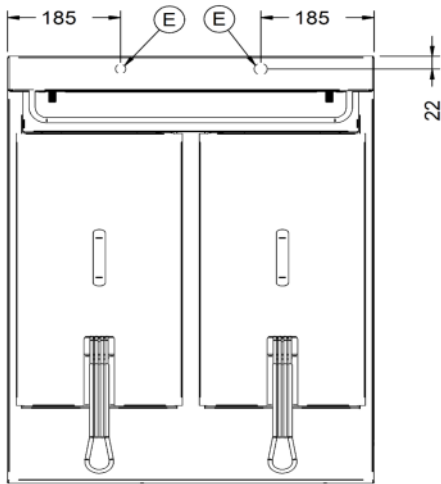

Lincat Limited

Whisby Road,
Lincoln, LN6 3QZ,
United Kingdom

Company No: 2175448

A member company of



Customer Care

Tel: +44 1522 875500
Email: care@lincat.co.uk

Export Customers

Tel: +44 1522 503250
Email: export@lincat.co.uk

Opening Hours

Monday – Friday:
8.30am – 5pm