



E9342F2 Twin Pan Filtration Fryer (Twin Pump / Twin Bucket Filtration)



Short Form Specification

Unit to be Falcon F900 Series high performance electric twin pan fryer. Pans will be 304 grade stainless steel. Unit to be supplied upon adjustable feet with a working oil capacity of 7.5 litres (*per pan*).

The pan will be of open well design to allow easy cleaning of the pan. Baskets to be positioned at pan rear for oil drain off and storage.

Oil to be drained from pans into oil buckets that are to be self-contained inside the unit base. The oil temperature will be thermostatically controlled via precise controls from 130-185°C. The unit will have safety thermostats fitted as standard to prevent unit from overheating. Unit has individual filtration to both pans and also filter buckets located below each pan.

The hob will be constructed from 2mm 304 grade stainless steel. Hobs will be laser cut with right-angled edges to allow joining of units with no gaps between hobs. Exterior panels are Scotch Brite finish stainless steel. Control knobs to be marked showing temperature positions with a bezel behind control knob to prevent water ingress.

Key Features

- “Eco” setting reduces power consumption during pre-heating and can be used as fat melt mode
- Integrated filtration to each pan extends oil life and reduces operation costs
- Two pressed pans can be drained individually
- Capacity is 7.5 litres (per pan)
- Elements rotate within pan for easy cleaning
- Manual control system for ease of use
- Rapid recovery and response times
- Fry plates, lid, drain buckets, filter mesh and baskets supplied as standard
- Individual bucket situated directly below each 1” drain valve
- IPX5 rated
- Supplied upon adjustable stainless steel feet
- 2mm thick 304 grade stainless steel hob
- Laser cut hob allows edge to edge joining of units
- Stainless steel external panels with Scotch Brite finish
- Dynamic Link System Compatible



Integrated linking system allows gap free installation to create a seamless, continuous cookline.

UK Patent No. 2540131

Optional Accessories

- Front hob rail
- Front and side kick strips
- Castors
- Side screens
- Hob extension



E9342F2 Twin Pan Filtration Fryer (Twin Pump / Twin Bucket Filtration)

Model Dimensions (mm)

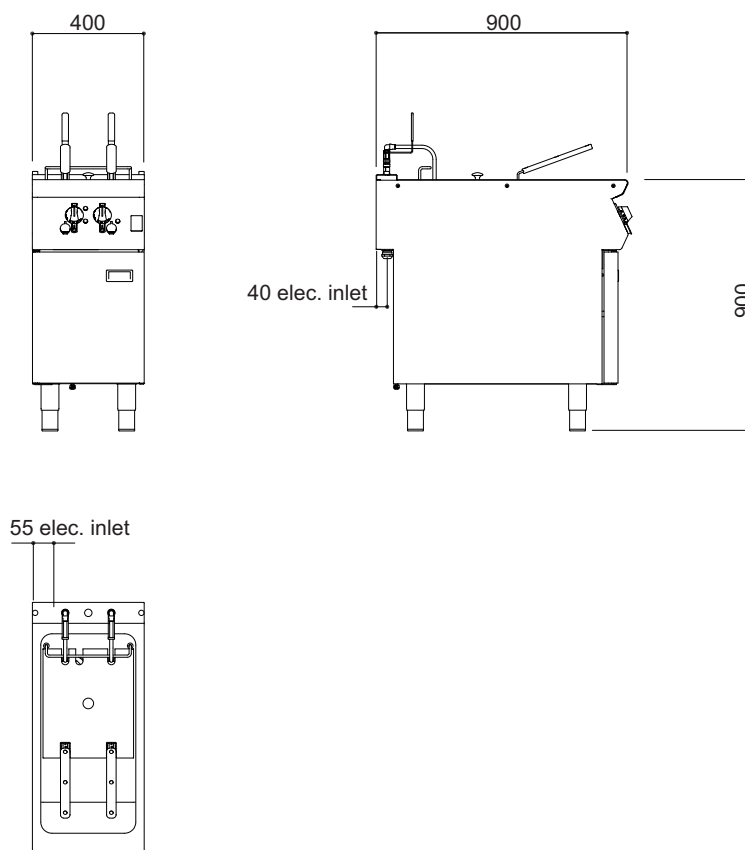

Specification Details

Electrical rating (kW)	15
Electrical supply voltage	400V 3N~ 50/60Hz
Required electrical supply (A)	32
Electrical current split (A)	L1: 21.74, L2: 21.74, L3: 21.74
Oil capacity (litres per pan)	7.5
Packed dimensions (mm)	490 (w) x 1000 (d) x 1015 (h)
Weight (kg)	78
Packed weight (kg)	88

Installation Note:

Please consult local legislation with regard to installation of cooking equipment.