

CATERWASH



Built by one of the largest most respected manufacturers in the world, this machine offers **outstanding performance, efficiency and reliability**. With a huge **18kg** capacity you can wash large bulky items such as king size duvets or wash more items in a single load.



- ✓ 1300rpm spin speed.
- ✓ 10 pre set wash cycles.
- ✓ 46 minute quick wash.
- ✓ Vibration control with 2 suspension springs and 4 dampers for quiet balanced washes.
- ✓ Add steam - to assist with loosening of stains and removing odours.
- ✓ Soil selection allows you to change the soil level depending on how dirty the load is.
- ✓ Extended tumble periodically tumbles the laundry up to 8 hours after the cycle to lessen the setting of creases.
- ✓ Pre-wash and extra rinse settings.

2 YEAR PARTS & LABOUR WARRANTY



Quality, affordable catering equipment & fantastic customer service

7 days a week, 8 am - 8pm - 01229 480001



Drain requirements

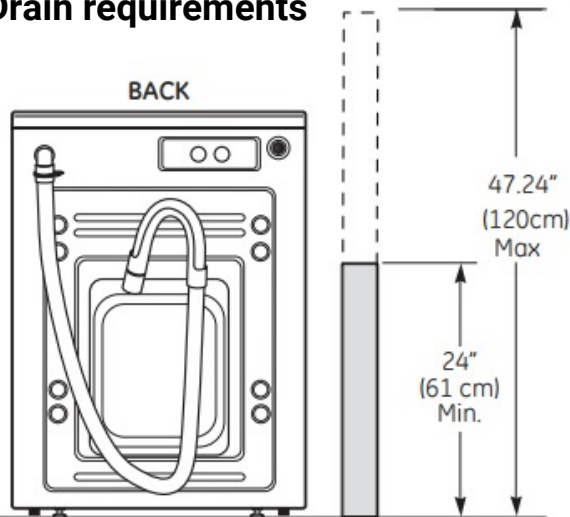

Specification

Weight	102kg
Load	18kg
Rated voltage	220-240V
Rated power	2100W
Motor power input per wash	300W
Motor power input for spin	800W
Pump input power	30W
Heating power input	1800W
Water pressure	0.1-0.8MPa
Grade of water proof	IPX4

